

# Housing Devices, Inc.

## ARCU-5 Area of Refuge Command Unit

### STANDARD FEATURES:

- Use with up to 5 ADA-1000 on the same phone line
- Coordinate and control in-building rescue in the event of an emergency
- Audible alert sounds when ADA-1000 places call until ADA-ARCU-5 joins conversation
- Rescue personnel pick up the ADA ARCU-5 phone and talk with ADA-1000 stations and any existing emergency call
- Brushed stainless steel face plate, steel enclosure, coil cord
- Full ADA, ASME A17 & B44 Elevator Code compliance
- Large engraved 3" Inch PUSH FOR HELP BUTTON
- Duplex communication
- Engraved lettering not silk screened
- 4 hours of full operation & standby upon loss of power
- PBX and Central office line cable
- Momentary Dry Contacts
- Automatic dialer with programmable 31 digit dialer memory

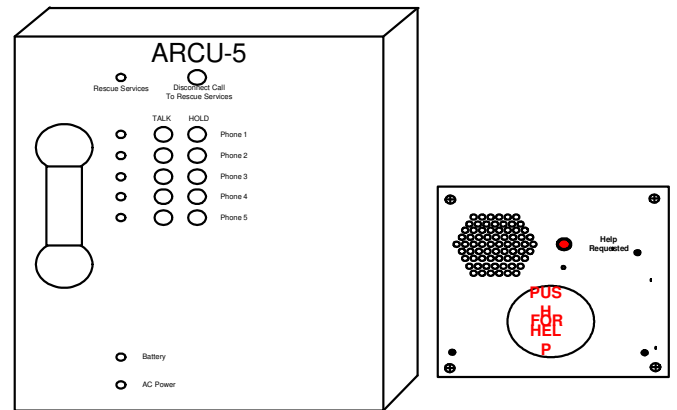

### DESCRIPTION:

The ADA ARCU-5 Area of Refuge Command Unit provides hands-free audio and visual alarms to users, Emergency Personnel, Offsite Communications & complies with the Americans with Disabilities Act. Installation is easily accomplished with connections to a telephone line, AC power & the ADA-1000. In the event of a power failure the ADA ARCU-5 & The ADA-1000 has an independent battery backup system.

### OPTIONAL FEATURES:

- Flush or Surface mounting (ADA-1000)
- Engraved Braille Signs
- Illuminated "Area of Rescue" Assistance Signs with or without Battery Back-Up
- Blue, Red, Amber or White strobes
- AC or DC power

### Model ADA-ARCU-5 Dimensions:

12-1/8"W x 12-1/8"H x 2-1/4"D

### Model ADA-1000 Dimensions:

9"W x 9"H x Flush

9-1/4"W x 9-1/4"H x 2" Surface

## SYSTEM OPERATION:

- All features of the ADA-1000 operate the standard way.
- The ADA-ARCU-5 allows emergency personnel to check the status of each zone and to talk with each ADA-1000 on an individual basis or all of them together.
- A lighted GREEN LED by Rescue Services indicates that an emergency call is in progress
- If an emergency call is in progress, by lifting the handset on the ADA-ARCU-5 unit you automatically join the conversation. At this point they can place any or all ADA-1000 on hold by pushing the hold button corresponding to that unit, this will leave them talking to the called party, or you can disconnect the called party by pressing the Disconnect Call to Rescue Services, this will leave you talking to the ADA-1000. (zones)
- If there is no emergency call in progress you can call into any or all ADA-1000 by pressing the corresponding TALK button on the unit

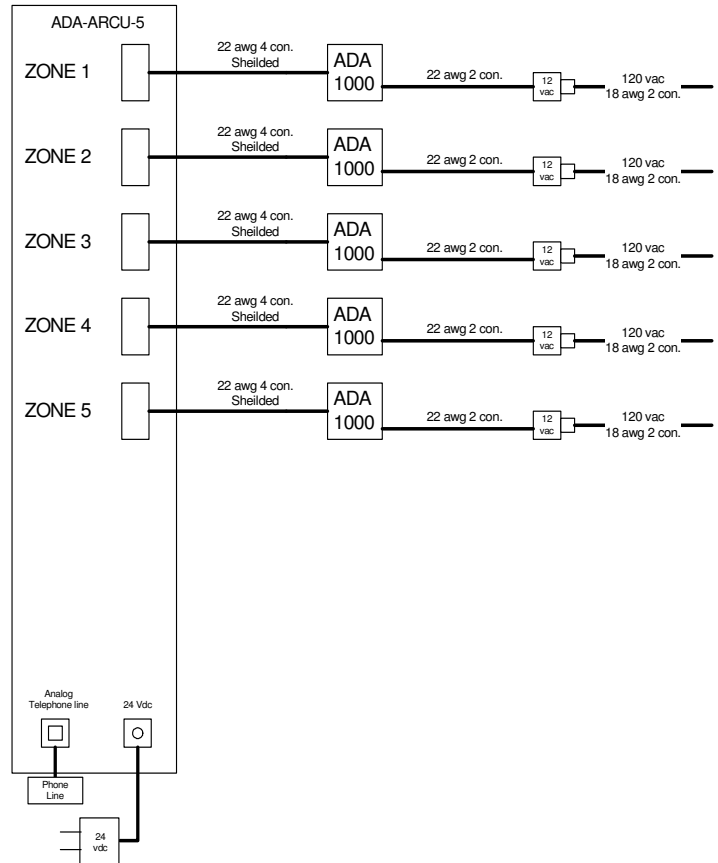

## BASIC SET-UP & WIRING:

- 120vac power
- 2 – wire analog telephone line to ADA-ARCU-5
- 4-wire connection between ADA-1000 & ADA-ARCU-5
- 120vac to 12vac step down transformer of the ADA-1000
- Remove cover by removing the 1 screw on both sides of the unit
- Connect battery terminal to battery (wire is marked with sticker)
- Surface or wall mounted (see template)
- Plug the 2 wire analog telephone line into the jack marked TELEPHONE LINE
- Plug each 4-wire line from the ADA-1000 into the jacks marked 1-5 corresponding to each zone
- Plug the power transformer into the ADA-ARCU-5 connector and into your 120vac source
- Re-mount the lid and attach the 2-screws

---

Notes: